



Electric Cylinders

series **E**

 **ROYAL**  
**CYLINDERS**

## Electric Cylinders

### Roller Screw and Ball Screw Technology

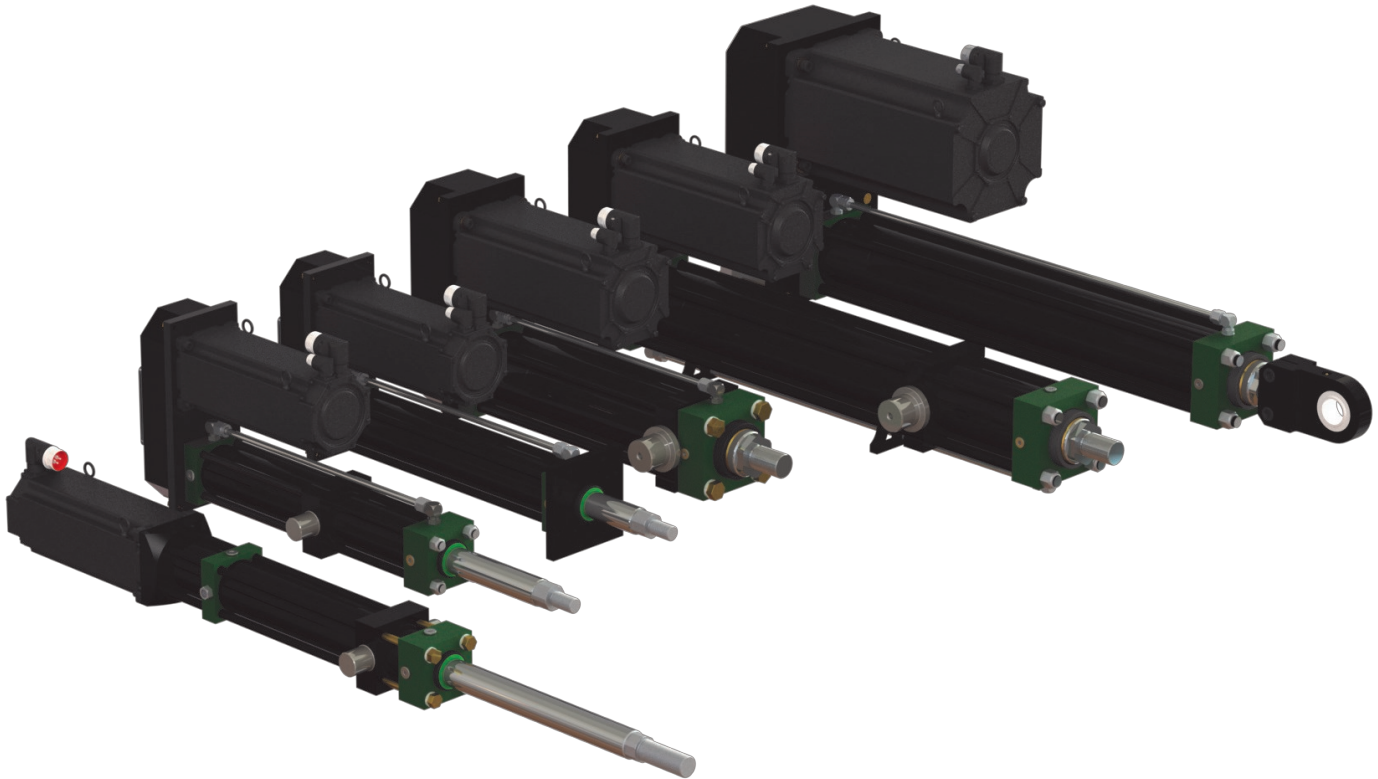

Westcoast Cylinders Inc.

225 Edworthy Way | New Westminster, BC V3L 5G4 | Canada  
(Ph): 604-527-1120 | (TF) 1-877-637-6925  
[www. RoyalCylinders.com](http://www.RoyalCylinders.com)  
Email: [Sales@royalcylinders.com](mailto:Sales@royalcylinders.com)

## Why Choose Royal

*Royal* actuators have been used in heavy duty applications in the resource industry since 1960. Our new E-Series actuators incorporate all of our proven features to provide a long life, heavy duty, and dependable solution that will exceed your expectations.

## Why Choose an Electric Actuator

Electric actuators offer a number of performance benefits compared to hydraulic & pneumatic actuators:

- Higher positional accuracy
- Direct control of the actuator without external influences – each actuator is independently controlled
- Eliminates fluid leaks – no line losses or environmental damage
- High energy efficiency – energy is only consumed during operation, not when idle
- Very High Stiffness – no bounce or “give” during operation
- Low maintenance requirements
- Less Noise for Quieter Operation

## Roller Screw or Ball Screw?

Our Roller Screw and Ball Screw actuators share the same advantages listed above with the only differences being the screw type and the load characteristics of that screw. Depending on your application, *Royal* will help you to determine which style is right for you.

### Ball Screw:

+/-23µm/300mm lead accuracy  
23,000 lbs max thrust loads

- ✓ Lighter Loads
- ✓ Long Life
- ✓ Less Precision
- ✓ Lower Cost

### Roller Screw:

+/- 23 µm/300mm lead accuracy  
70,000 lbs max thrust loads

- ✓ High Loads
- ✓ Longer Life
- ✓ Higher Speeds
- ✓ Repeatable Precision

## The *Royal* Advantage

### HEAVY DUTY CONSTRUCTION

#### All Steel Construction

- Designed around our proven hydraulic cylinder line

#### Industrial Mounts

- Trunnion mounts come with wearable pins
- Plate mounts oversized for more support
- Custom mounts available

#### Solid, One Piece Output Shaft

- One piece design allows for maximum strength and flawless finish
- Strongest shaft on the market

### HIGH QUALITY MATERIALS

#### Nitrided Piston Rods

- Higher Corrosion Resistance
- Better Wear ability
- Resists Impacts better than chrome
- Increase life of seals and wipers

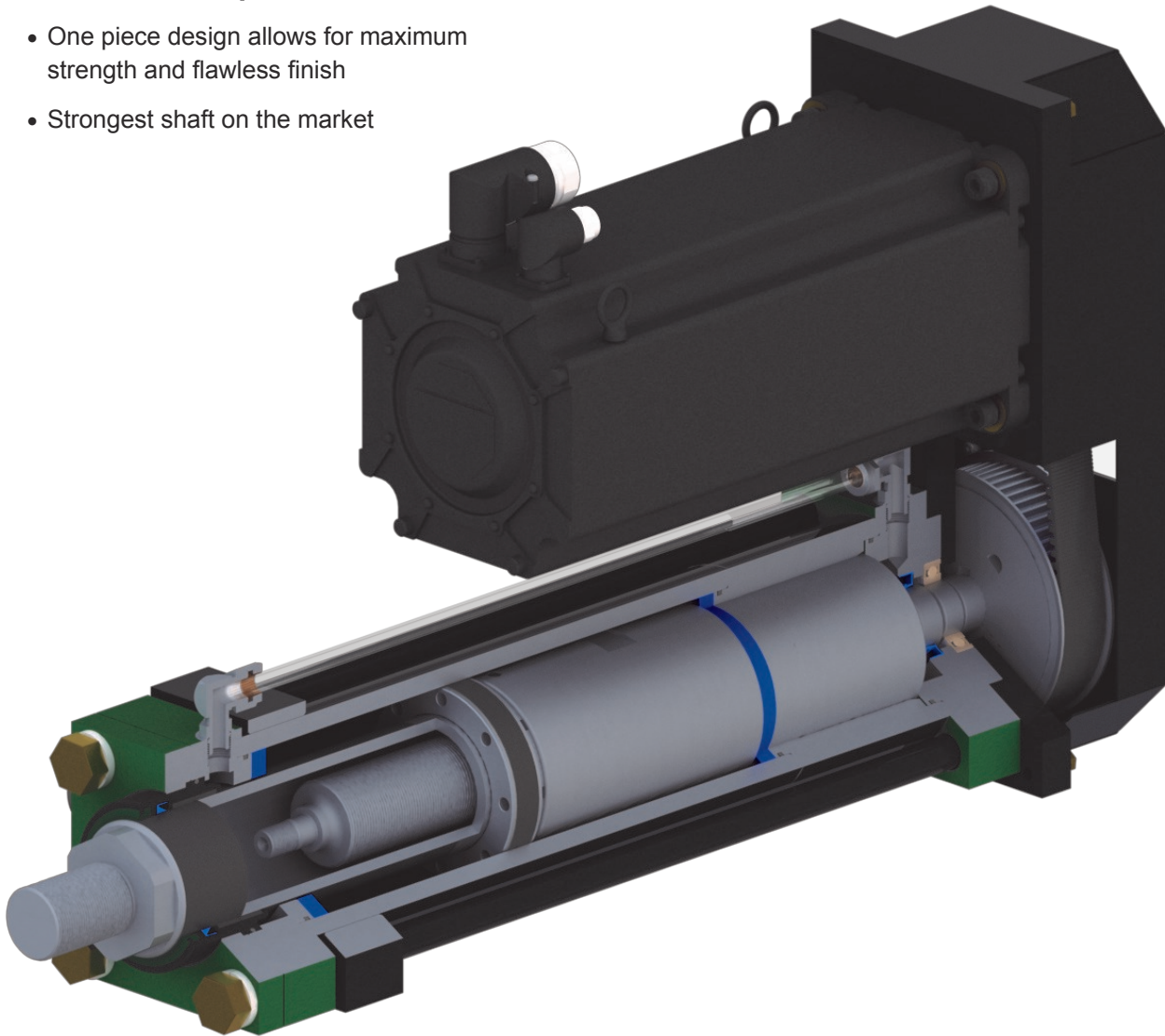

## IMPACT PROTECTION

Designed for high impact forces

### Heavy Duty Internal Bumpers

- Reduce unintended impact on the expensive internal components

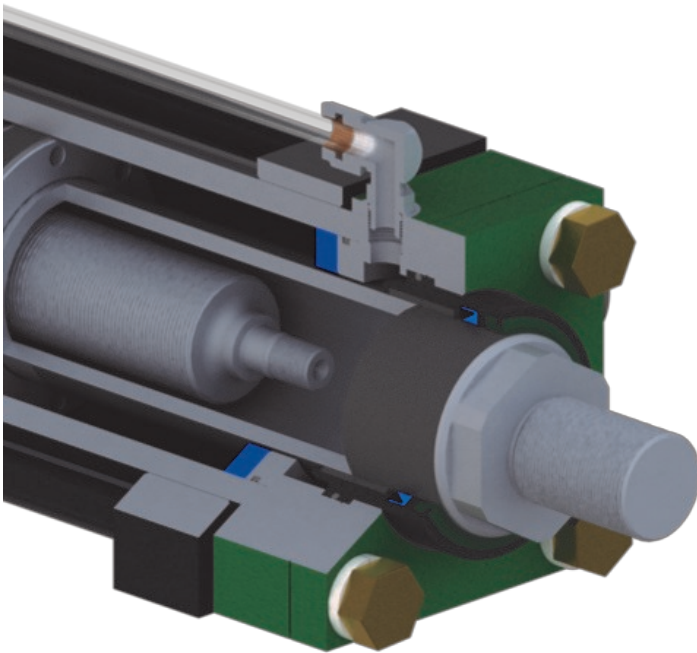

## INDUSTRIAL ADVANTAGES

### Durable Wipers and Scrapers

- Heavy duty rod wipers or optional solid brass scrapers protect the internals from damage in the toughest of applications

### Dual Gland Wear Strips

- Wear Strips eliminates gland bushing wear leading to longer life

## Selection

We can work with you to custom design a cylinder for your application

- Any Stroke
- Any Mounting Style

## E32 Model

### Model Specifications

Base Model No.	Housing Bore Size (in)	Screw Dia. (mm)	Screw Lead (mm)	Stroke (in)	Max Linear Screw Speed (in/sec)	Screw Dynamic Load Ratings* (lbf)	Max Screw Static Force (lbf)	Max Screw Rotational Speed (rpm)	Max Allowable Thrust Load (lbs)
E32	3 1/4	30	5	6	15.7	31,855	67,000	4,800	38,000
E32	3 1/4	30	5	12	15.7	31,855	67,000	4,800	38,000
E33	3 1/4	30	5	24	15.7	31,855	67,000	4,800	38,000
E32	3 1/4	30	30	6	94.5	32,686	69,000	4,800	38,000
E32	3 1/4	30	30	12	94.5	32,686	69,000	4,800	38,000
E32	3 1/4	30	30	24	94.5	32,686	69,000	4,800	38,000
E32	3 1/4	36	12	6	31.5	27,494	58,000	4,000	38,000
E32	3 1/4	36	12	12	31.5	27,494	58,000	4,000	38,000
E32	3 1/4	36	12	24	31.5	27,494	58,000	4,000	38,000

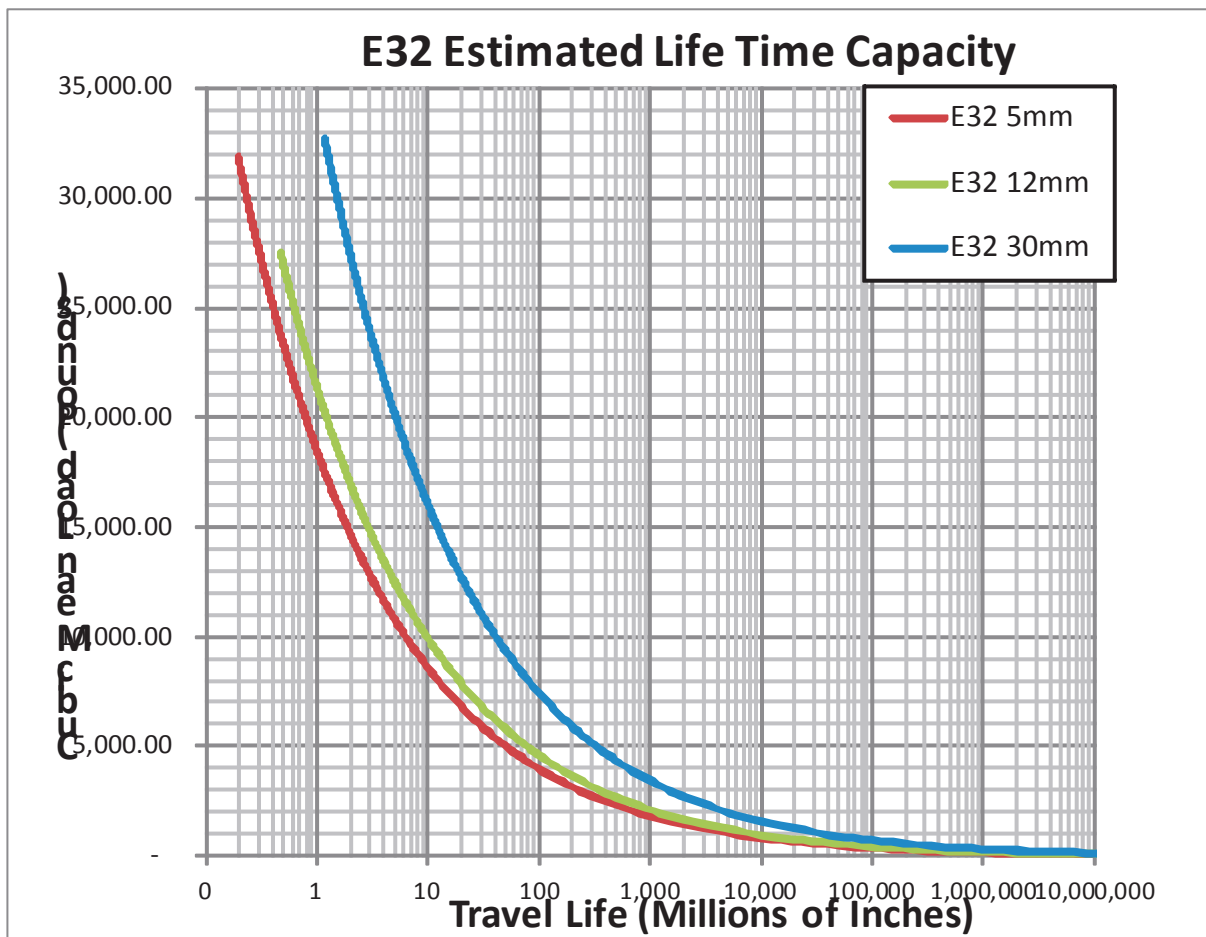

## E50 Model

### Model Specifications

Base Model No.	Housing Bore Size (in)	Screw Diameter (mm)	Screw Lead (mm)	Stroke (in)	Max Linear Screw Speed (in/sec)	Screw Dynamic Load Ratings* (lbf)	Max Screw Static Force (lbf)	Max Screw Rotational Speed (rpm)	Max Allowable Thrust Load (lbs)
E50	5.00	56	12	6	20.5	103,055	217,500	2,600	70,000
E50	5.00	56	12	12	20.5	103,055	217,500	2,600	70,000
E50	5.00	56	12	24	20.5	103,055	217,500	2,600	70,000
E50	5.00	56	30	6	51.2	135,528	293,000	2,600	70,000
E50	5.00	56	30	12	51.2	135,528	293,000	2,600	70,000
E50	5.00	56	30	24	51.2	135,528	293,000	2,600	70,000
E50	5.00	56	30	36	51.2	135,528	293,000	2,600	70,000

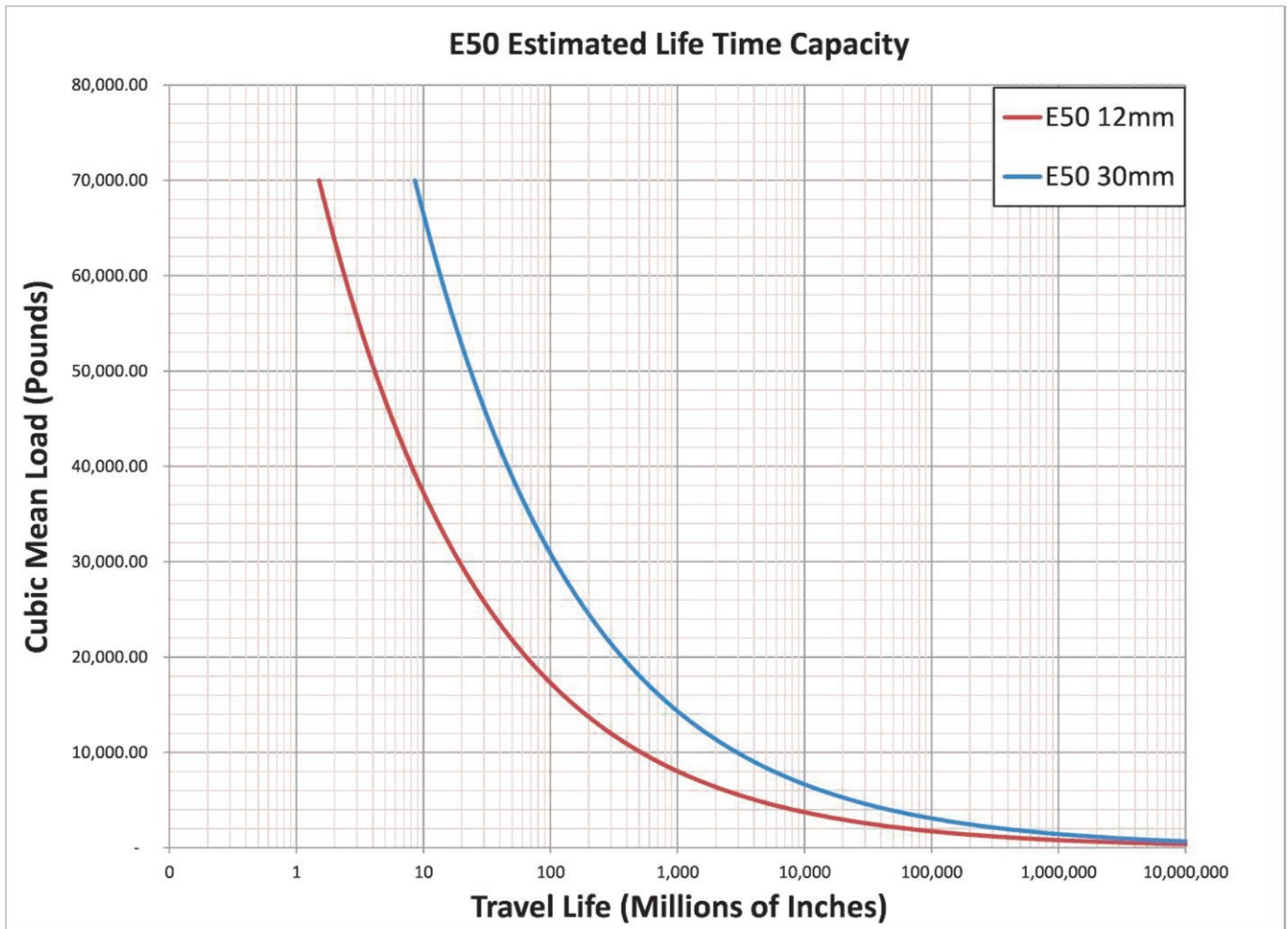

## Applications

Royal Electric E-series cylinder was designed originally to solve the high demands of the veneer and plywood productions industry. With our experience in designing durable cylinders we set out and developed the toughest electric cylinder on the world market today.



Working with *Altec Integrated Technology*, who designs and builds the machinery and systems controls for the veneer industry, we introduced our cylinders in the toughest application imaginable, a Veneer Charger and Lathe Carriage.

### To date in this application:

- Trusted in over 15 different Mills in North America
- 125 Cylinders Engineered and Manufactured
- Successful running hours and increased reliability

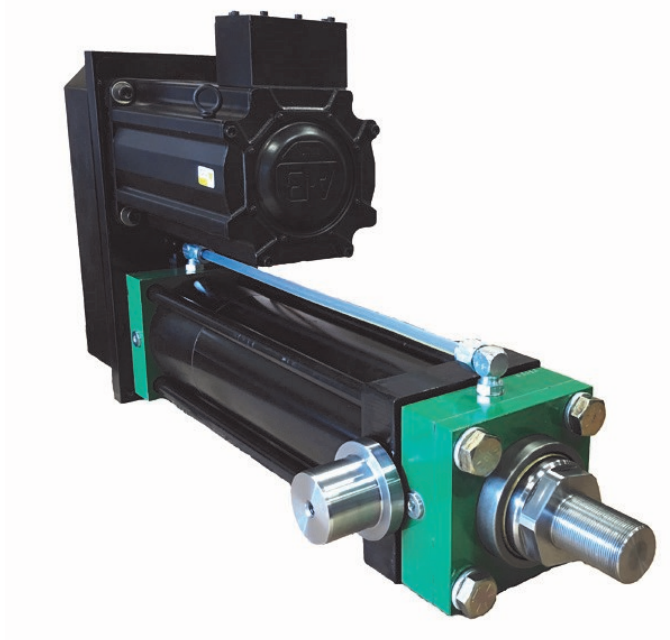



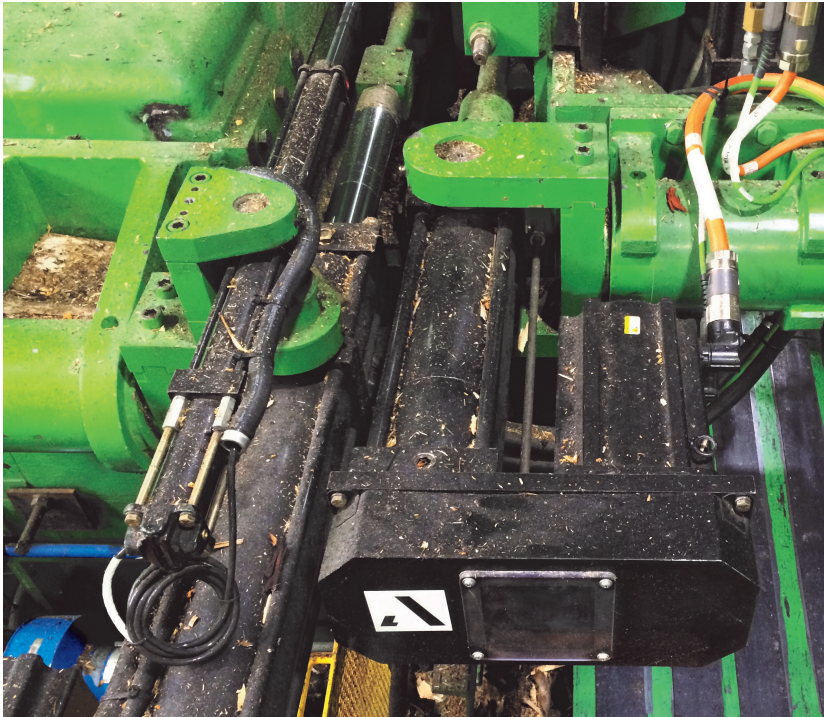

# Application Specification Worksheet

Fill in below data as best you can.  
Not all information is required, contact us for questions

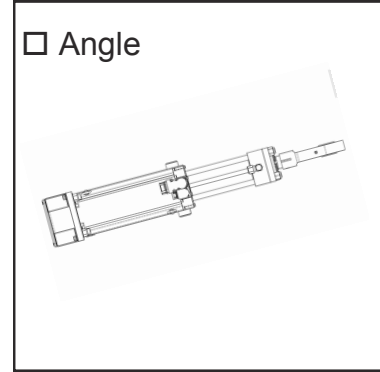
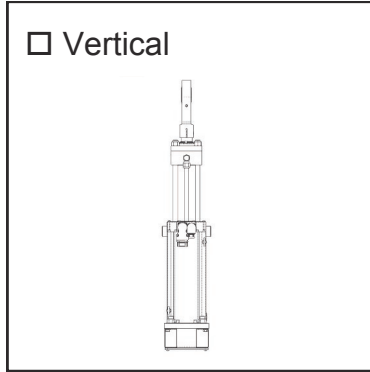
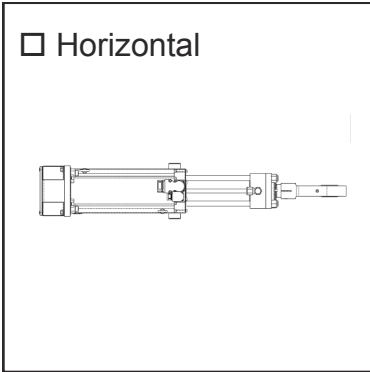

## MOUNTING STYLE

- Clevis       Foot       Rod End Sq. Flange       Rod End Rect. Flange  
 Side Tapped       Trunnion Head       Mid-Trunnion XI= \_\_\_\_\_       Other: \_\_\_\_\_

## LIFE PROFILE

Number of Cycles: \_\_\_\_\_      Use hours per day: \_\_\_\_\_      Days per week \_\_\_\_\_  
 per minute       per hour

## MOVEMENT AND LOADS

### EXTEND

Load \_\_\_\_\_  lbs  kg  
 Travel \_\_\_\_\_  inches  mm  
 Time \_\_\_\_\_ secs  
 Max Speed \_\_\_\_\_  in/secs  mm/sec

### RETRACTED

Load \_\_\_\_\_  lbs  kg  
 Travel \_\_\_\_\_  inches  mm  
 Time \_\_\_\_\_ secs  
 Max Speed \_\_\_\_\_  in/secs  mm/sec

Additional Information:

# Motor Mounting Orientation

Parallel

Inline

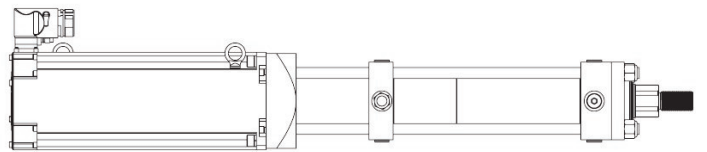
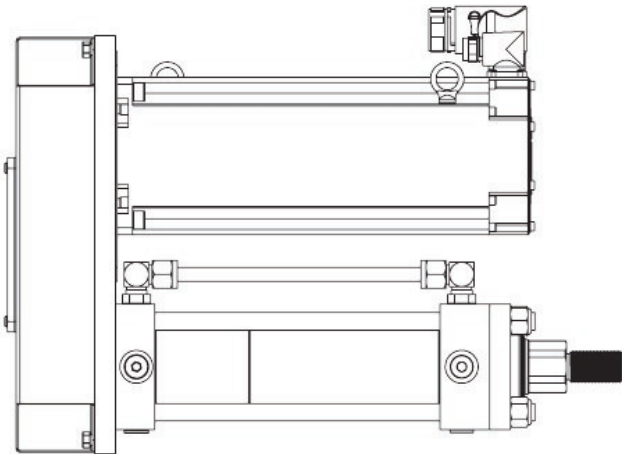
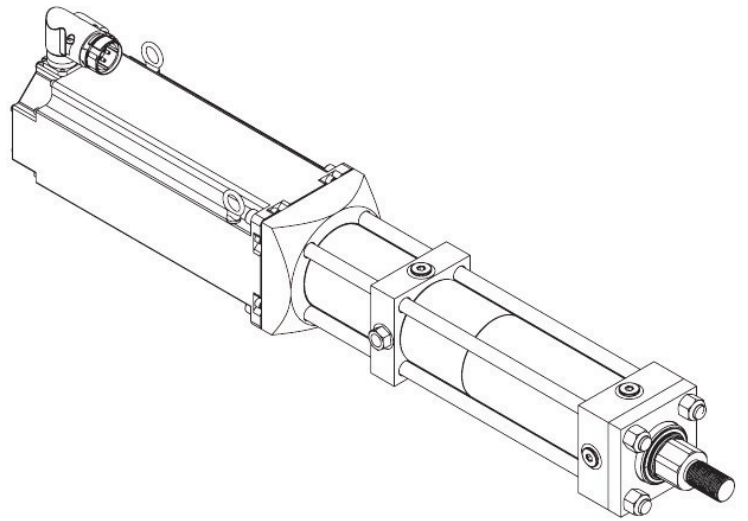
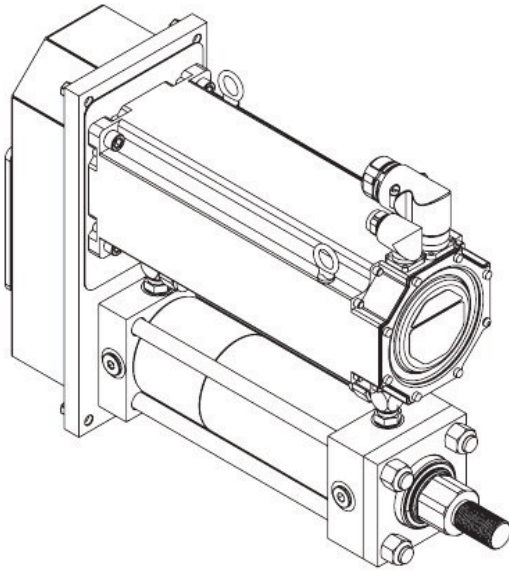

## Mounting Styles

### 3.25 inch Bore Rod End Sq. Flange

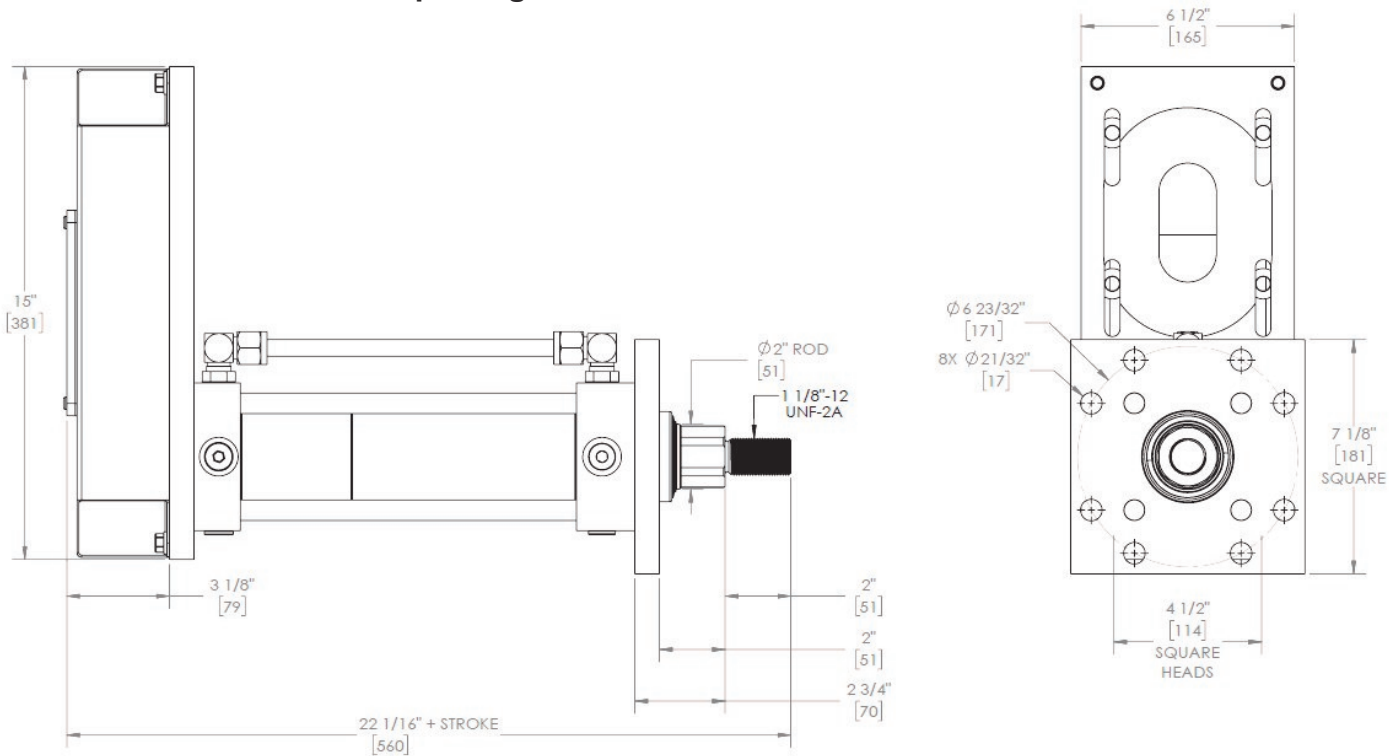

### 3.25 inch Bore Rod Mid Trunnion

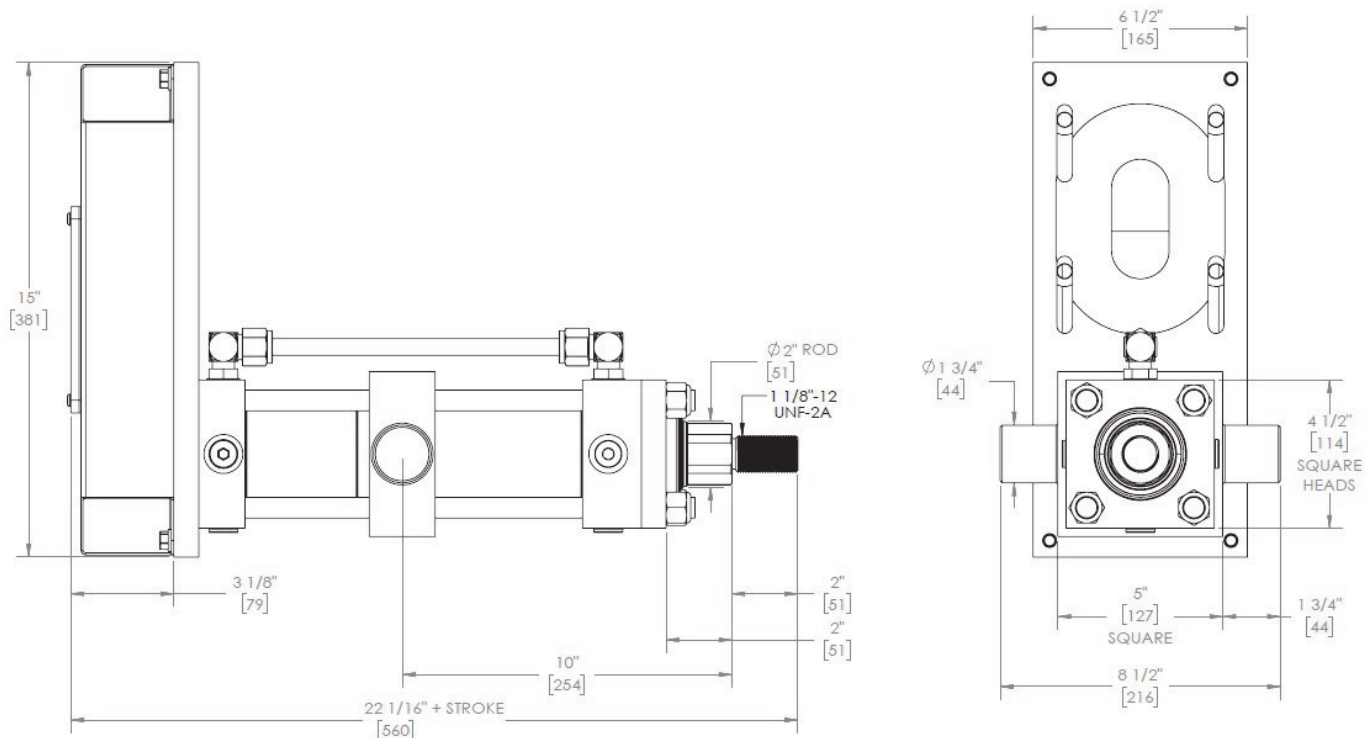

# Mounting Styles

## 3.25 inch Bore Rear Clevis

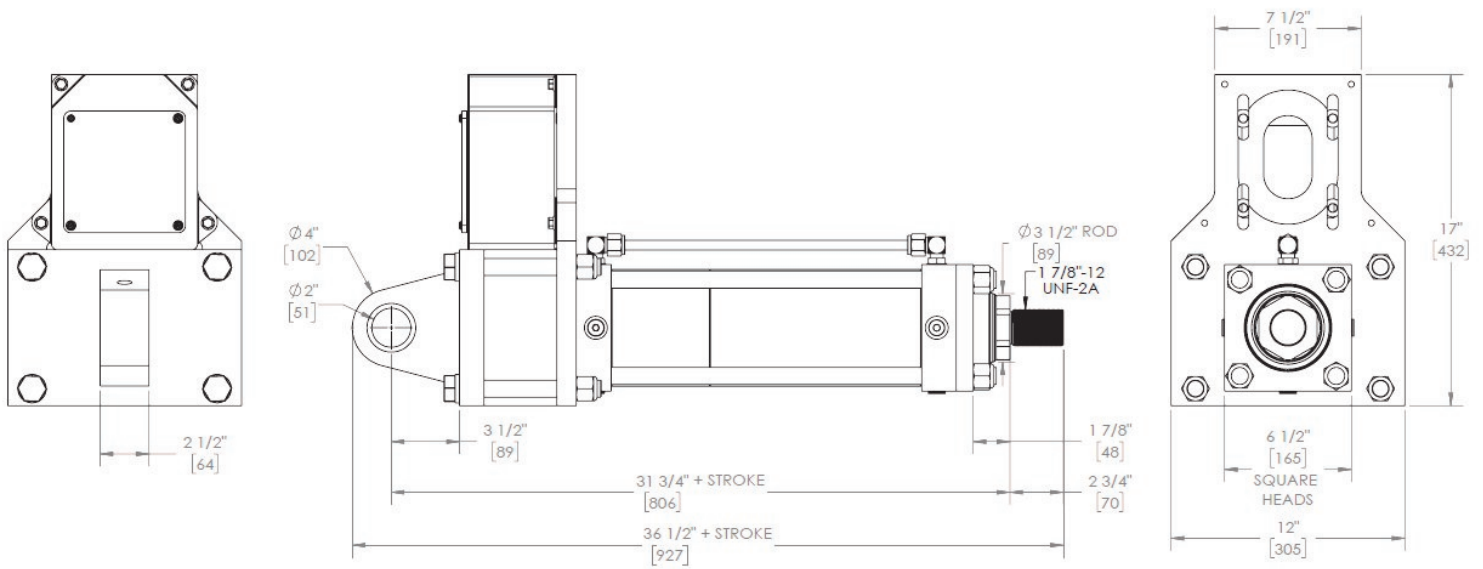

## Mounting Styles

### 5 inch Bore Rod Rear Clevis

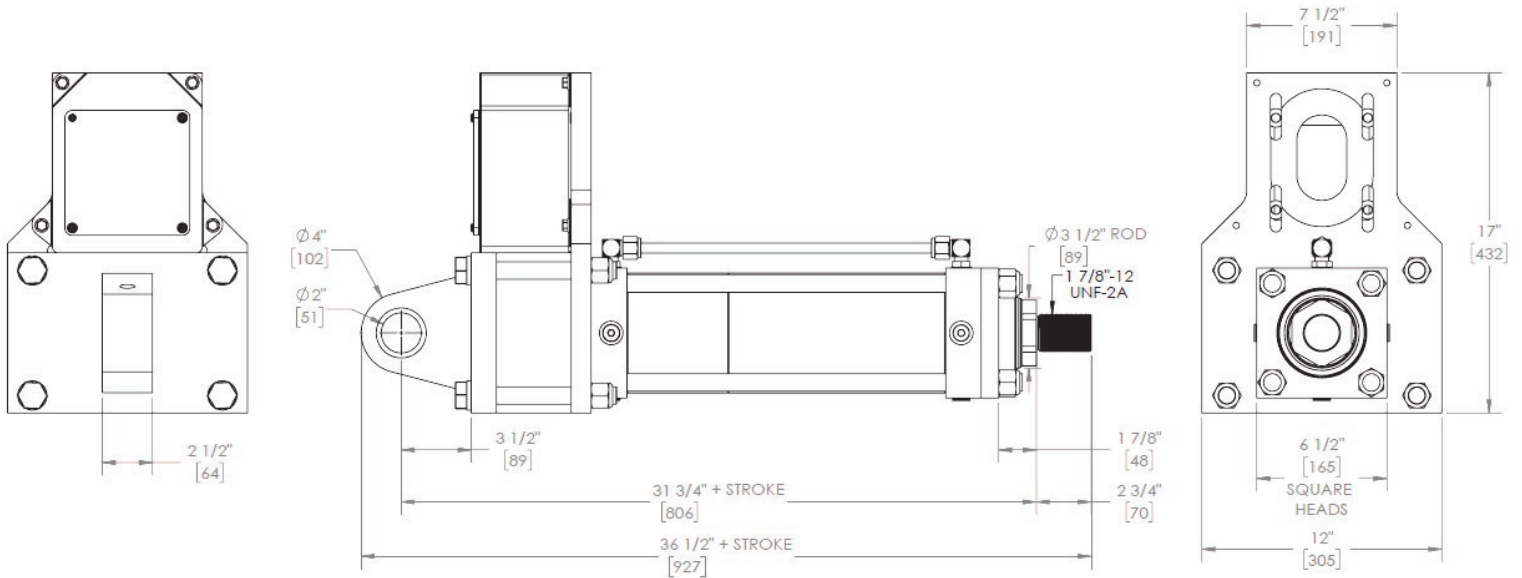

### 5 inch Bore Rod Head Trunnion

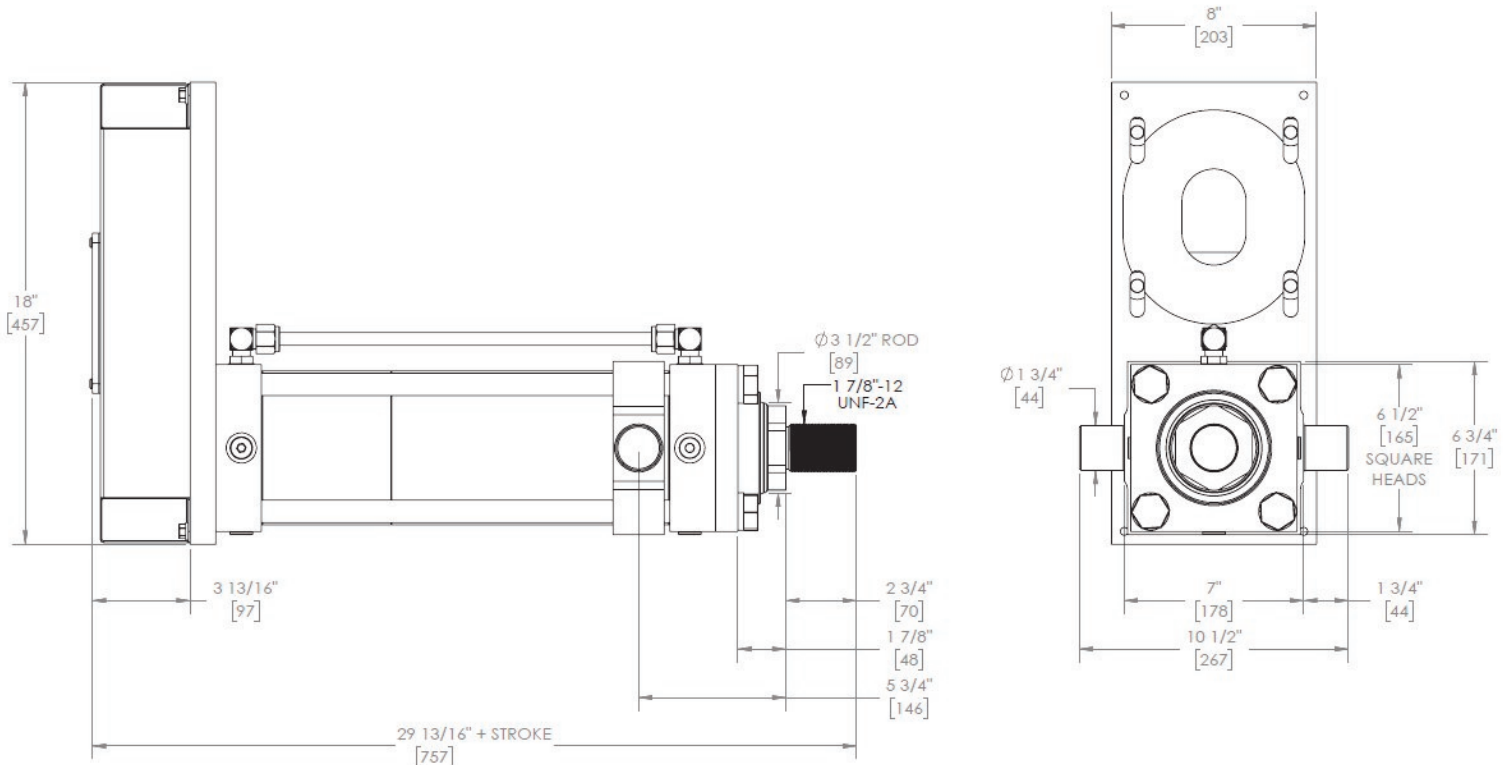

## Mounting Styles

### 5 inch Bore Rod End Sq. Flange

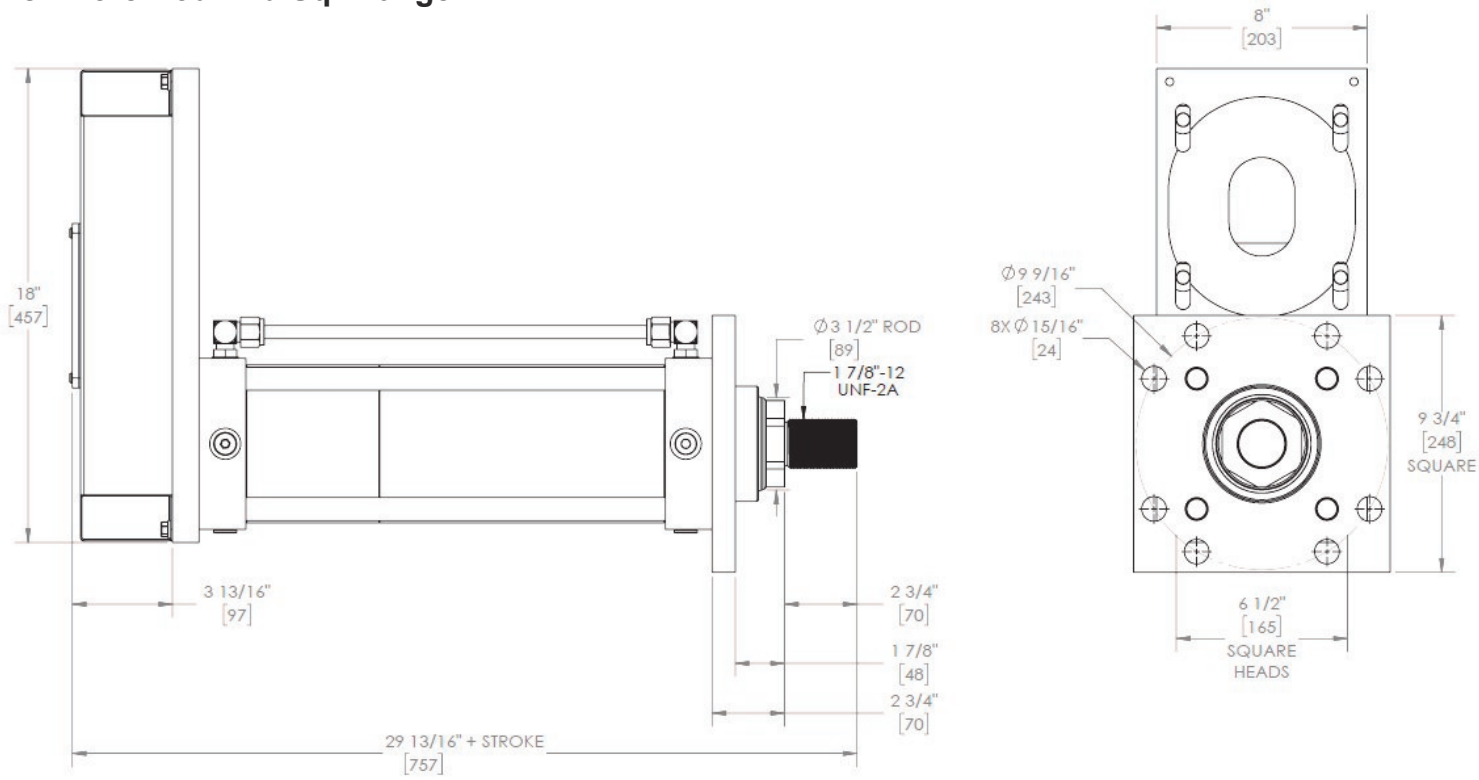

### 5 inch Bore Mid Trunnion

